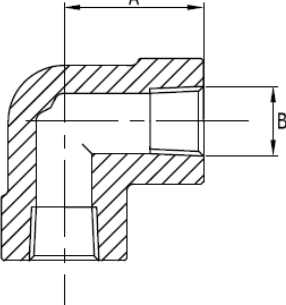
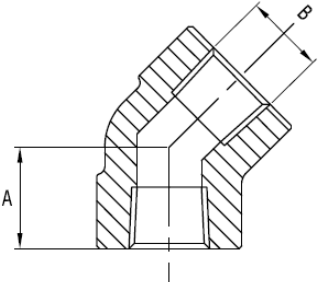
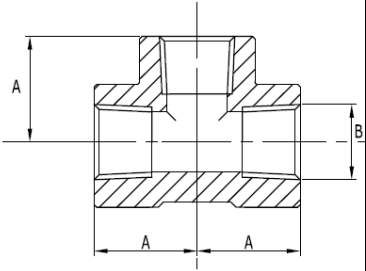
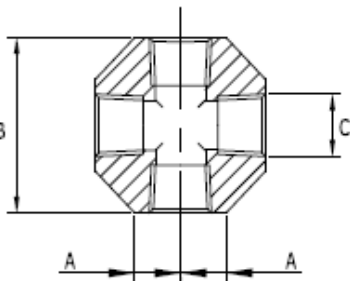

**Data Sheet**

**NPT ANSI B16.11/BS3799 3000lb and 6000lb Fittings**

| NPT Screwed Equal 90° Elbow   | Size<br>"B"<br>NPT            | Dimension "A"      |               |        |        | Part No: |
|---|-------------------------------|--------------------|---------------|--------|--------|----------|
|   |                               | 3000lb             |               | 6000lb |        |          |
|    | 1/8"                          | 0.812              | 21            | -      | -      |          |
|   | 1/4"                          | 1.000              | 25            | -      | -      |          |
|   | 3/8"                          | 1.125              | 29            | -      | -      |          |
|   | 1/2"                          | 1.312              | 33            | 1.500  | 38     |          |
|   | 3/4"                          | 1.500              | 38            | 1.750  | 44     |          |
|   | 1"                            | 1.750              | 44            | 2.00   | 51     |          |
|   | 1 1/4"                        | 2.000              | 51            | 2.375  | 60     |          |
|   | 1 1/2"                        | 2.375              | 60            | 2.500  | 64     |          |
|   | 2"                            | 2.500              | 64            | 3.250  | 83     |          |
|   | 2 1/2"                        | 3.250              | 83            | 3.750  | 95     |          |
|   | 3"                            | 3.750              | 95            | 4.500  | 114    |          |
|   | NPT Screwed Equal 45° Elbow   | Size<br>"B"<br>NPT | Dimension "A" |        |        |          |
| 3000lb  |                               |                    | 6000lb        |        |        |          |
|   | 1/8"                          | 0.812              | 21            | -      | -      |          |
|   | 1/4"                          | 1.000              | 25            | -      | -      |          |
|   | 3/8"                          | 1.125              | 29            | -      | -      |          |
|   | 1/2"                          | 1.312              | 33            | 1.500  | 38     |          |
|   | 3/4"                          | 1.500              | 38            | 1.750  | 44     |          |
|   | 1"                            | 1.750              | 44            | 2.00   | 51     |          |
|   | 1 1/4"                        | 2.000              | 51            | 2.375  | 60     |          |
|   | 1 1/2"                        | 2.375              | 60            | 2.500  | 64     |          |
|   | 2"                            | 2.500              | 64            | 3.250  | 83     |          |
|   | 2 1/2"                        | 3.250              | 83            | 3.750  | 95     |          |
|   | 3"                            | 3.750              | 95            | 4.500  | 114    |          |
|   | NPT Screwed Equal Tee         | Size<br>"B"<br>NPT | Dimension "A" |        |        |          |
| 3000lb  |                               |                    | 6000lb        |        |        |          |
|  | 1/8"                          | 0.812              | 21            | -      | -      |          |
|   | 1/4"                          | 1.000              | 25            | -      | -      |          |
|   | 3/8"                          | 1.125              | 29            | -      | -      |          |
|   | 1/2"                          | 1.312              | 33            | 1.500  | 38     |          |
|   | 3/4"                          | 1.500              | 38            | 1.750  | 44     |          |
|   | 1"                            | 1.750              | 44            | 2.00   | 51     |          |
|   | 1 1/4"                        | 2.000              | 51            | 2.375  | 60     |          |
|   | 1 1/2"                        | 2.375              | 60            | 2.500  | 64     |          |
|   | 2"                            | 2.500              | 64            | 3.250  | 83     |          |
|   | 2 1/2"                        | 3.250              | 83            | 3.750  | 95     |          |
|   | 3"                            | 3.750              | 95            | 4.500  | 114    |          |
|   | NPT Equal Screwed Equal Cross | Size<br>"B"<br>NPT | Dimension "A" |        |        |          |
| 3000lb  |                               |                    | 6000lb        | 3000lb | 6000lb |          |
|  | 1/8"                          | 0.812              | 21            | -      | -      |          |
|   | 1/4"                          | 1.000              | 25            | -      | -      |          |
|   | 3/8"                          | 1.125              | 29            | -      | -      |          |
|   | 1/2"                          | 1.312              | 33            | 1.500  | 38     |          |
|   | 3/4"                          | 1.500              | 38            | 1.750  | 44     |          |
|   | 1"                            | 1.750              | 44            | 2.00   | 51     |          |
|   | 1 1/4"                        | 2.000              | 51            | 2.375  | 60     |          |
|   | 1 1/2"                        | 2.375              | 60            | 2.500  | 64     |          |
|   | 2"                            | 2.500              | 64            | 3.250  | 83     |          |
|   | 2 1/2"                        | 3.250              | 83            | 3.750  | 95     |          |
|   | 3"                            | 3.750              | 95            | 4.500  | 114    |          |

**Data Sheet**

**NPT ANSI B16.11/BS3799 3000lb and 6000lb Fittings**

| NPT Hex Nipple        |  |          |               |      |           |  |
|-----------------------|--|----------|---------------|------|-----------|--|
| Size NPT              | A  | B        | C             | TPI  | Part Nos: |  |
| 1/8"                  | 10.0   | 25.4     | 9.5           | 27   |           |  |
| 1/4"                  | 12.7   | 32.0     | 12.5          | 18   |           |  |
| 3/8"                  | 12.7   | 33.3     | 15.9          | 18   |           |  |
| 1/2"                  | 16.0   | 39.7     | 19.8          | 14   |           |  |
| 3/4"                  | 19.0   | 44.4     | 25.1          | 14   |           |  |
| 1"                    | 21.0   | 50.8     | 31.5          | 11.5 |           |  |
| 1 1/4"                | 21.0   | 55.5     | 40.2          | 11.5 |           |  |
| 1 1/2"                | 22.2   | 60.3     | 46.3          | 11.5 |           |  |
| 2"                    | 24.0   | 65.0     | 58.3          | 11.5 |           |  |
| 2 1/2"                | 32.0   | 82.5     | 70.2          | 8    |           |  |
| 3"                    | 34.0   | 85.7     | 86.1          | 8    |           |  |
| NPT Hex Plug          |  |          |               |      |           |  |
| Size NPT              | Thread   | A        | B             | TPI  | Part Nos: |  |
| 1/8"                  | 10.0   | 16.0     | 9.5           | 27   |           |  |
| 1/4"                  | 12.7   | 19.0     | 12.5          | 18   |           |  |
| 3/8"                  | 12.7   | 20.5     | 15.9          | 18   |           |  |
| 1/2"                  | 16.0   | 24.0     | 19.8          | 14   |           |  |
| 3/4"                  | 19.0   | 27.0     | 25.1          | 14   |           |  |
| 1"                    | 21.0   | 30.0     | 31.5          | 11.5 |           |  |
| 1 1/4"                | 21.0   | 35.0     | 40.2          | 11.5 |           |  |
| 1 1/2"                | 22.2   | 38.0     | 46.3          | 11.5 |           |  |
| 2"                    | 24.0   | 43.0     | 58.3          | 11.5 |           |  |
| 2 1/2"                | 32.0   | 51.0     | 70.2          | 8    |           |  |
| 3"                    | 34.0   | 54.0     | 86.1          | 8    |           |  |
| NPT Hex Reducing Bush |  |          |               |      |           |  |
| Size B                | Size C   | Length A |               | TPI  | Part Nos: |  |
| 1/4"                  | Reduction size to be confirmed by the customer | 16.0     |               | 18   |           |  |
| 3/8"                  |  | 17.0     |               | 18   |           |  |
| 1/2"                  |  | 21.0     |               | 14   |           |  |
| 3/4"                  |  | 24.0     |               | 14   |           |  |
| 1"                    |  | 27.0     |               | 11.5 |           |  |
| 1 1/4"                |  | 28.0     |               | 11.5 |           |  |
| 1 1/2"                |  | 30.0     |               | 11.5 |           |  |
| 2"                    |  | 33.0     |               | 11.5 |           |  |
| 2 1/2"                |  | 42.0     |               | 8    |           |  |
| 3"                    |  | 47.0     |               | 8    |           |  |
| NPT Round End Cap     |  |          |               |      |           |  |
| Size NPT              | A  | B        | Gauge Plane C | TPI  | Part Nos: |  |
| 1/8"                  | 19.0   | 16.0     | 9.5           | 27   |           |  |
| 1/4"                  | 25.0   | 19.0     | 12.5          | 18   |           |  |
| 3/8"                  | 25.0   | 22.0     | 15.9          | 18   |           |  |
| 1/2"                  | 32.0   | 29.0     | 19.8          | 14   |           |  |
| 3/4"                  | 37.0   | 35.0     | 25.1          | 14   |           |  |
| 1"                    | 41.0   | 45.0     | 31.5          | 11.5 |           |  |
| 1 1/4"                | 45.0   | 57.0     | 40.2          | 11.5 |           |  |
| 1 1/2"                | 45.0   | 64.0     | 46.3          | 11.5 |           |  |
| 2"                    | 48.0   | 76.0     | 58.3          | 11.5 |           |  |
| 2 1/2"                | 60.0   | 92.0     | 70.2          | 8    |           |  |
| 3"                    | 65.0   | 108.0    | 86.1          | 8    |           |  |

**Data Sheet**

**NPT ANSI B16.11/BS3799 3000lb and 6000lb Fittings**

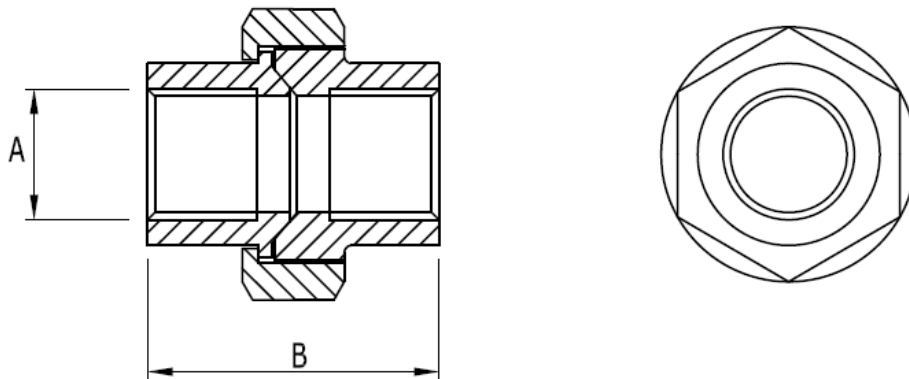

| NPT / BSPT Cone Seat Union   | Size<br>NPT /<br>BSPT | B     | C | D | TPI  | Part Nos: |
|--|-----------------------|-------|---|---|------|-----------|
| <b>Options:</b> <ul style="list-style-type: none"> <li>• Female x Female</li> <li>• Male x Male</li> <li>• Male x Female</li> <li>• Socket Weld</li> </ul> | 1/8"                  | 40.0  |   |   | 27   |           |
|  | 1/4"                  | 43.0  |   |   | 18   |           |
|  | 3/8"                  | 48.0  |   |   | 18   |           |
|  | 1/2"                  | 51.0  |   |   | 14   |           |
|  | 3/4"                  | 57.0  |   |   | 14   |           |
|  | 1"                    | 64.0  |   |   | 11.5 |           |
|  | 1 1/4"                | 70.0  |   |   | 11.5 |           |
|  | 1 1/2"                | 79.0  |   |   | 11.5 |           |
|  | 2"                    | 89.0  |   |   | 11.5 |           |
|  | 2 1/2"                | 118.0 |   |   | 8    |           |
|  | 3"                    | 121.0 |   |   | 8    |           |