

Data Sheet

Pump Protection Strainers

These compact mini-strainers are frequently used for pump protection and where space is at a premium. The strainer is useful where flow rates seldom exceed 10 M³/hour. The standard Wedge Wire element ratings range from 50 to 2000 Micron and specials can be manufactured to suit your particular application.

Housings are available to suit 3" and 4" connections sizes.

Perforated elements can also be supplied in 1.0mm, 1.5mm, 3.0mm and 10.0mm ratings.



Features and options:

- Compact design suitable for confined spaces
- Ideal for pump protection duties
- Fully Interchangeable wedge wire elements
- Flow rate capacity up to 10M³/H
- Standard Inlet sizes from 1", to 4"
- Standard slot tubes sizes from 25 to 2000 micron
- All 316L stainless steel construction
- Jacketed housings and duplex arrangements
- Metal to metal housing to element seating
- No tools required for dismantling and servicing
- Full range of FDA food grade seals
- Long life expectancy
- Range of surface finishes offered
- Backflushing possible at up to 75% working pressure
- 7 Bar working pressure
- Fully welded and robust wedge wire element

Data Sheet

Pump Protection Strainers

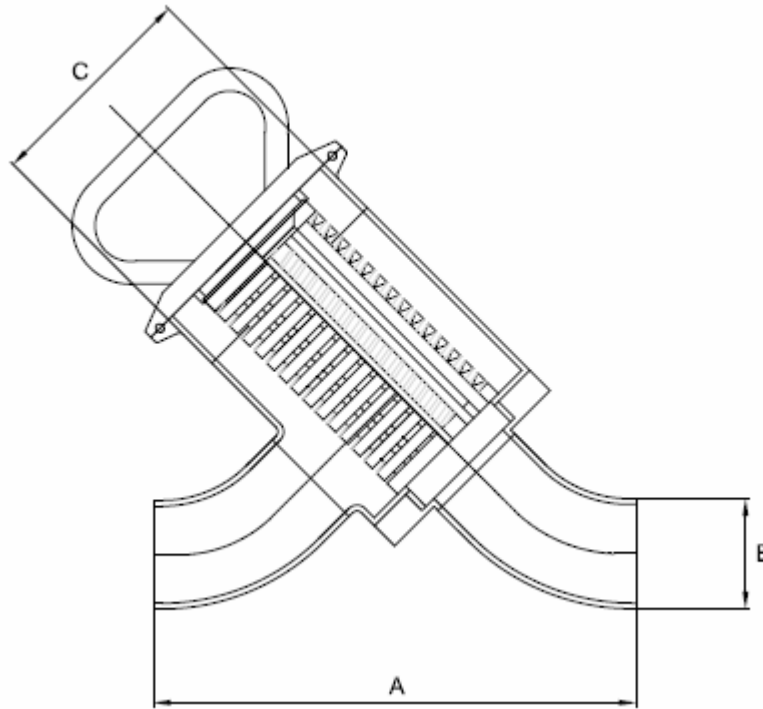

Part No:	Line Size	A	B	C	Series
2082-A026	1"	165	25.5	3"	S350
2082-A038	1 ½"	240	38.1	3"	S350
2082-A051	2"	260	50.8	3"	S350
2082-A064	2 ½"	400	63.5	4"	S450
2082-A076	3"	300	76.2	4"	S450
2082-A102	4"	445	101.6	6"	S650

Options:

- High Flow rate capacity – up to 10 M³/Hour
- Choice of FDA approved seal materials
- Wedge wire elements from 25 Micron to 3000
- 7 Bar working pressure
- Standard dull polished finish
- **Final dimension to be confirmed at order stage**